

LUMP BREAKER E 600



CRUSHES AND BREAKS UP BULK AND COMPRESSED GRANULATED MATERIALS.

SPECIFICATIONS

CONSTRUCTION	Frame in sheet metal, painted steel or 304L or 316L stainless steel
WEIGHT	250 kG
FEED	By gravity
ROTOR	With 12 knives fixed to 2 slats arranged in a helix
SPEED OF ROTATION	50 rpm
TRANSMISSION	Direct at shaft end with reaction arm
MOTORISATION	Motor-gearbox with hollow shaft, 2.2 kW
GRIDS	Perforated grid to carry out a granulometric check on output or comb with bars (depending on the nature of the products)
EQUIPMENT OPTIONAL	Hopper for manual loading Output chute Mounting frame

USES

Agri-foodstuffs: copolymers, rusks, adipic acid, etc.
Chemical fertilizers: nitrates and ammonium bi-fluoride, etc.
By-products: incinerator slags, polystyrene crates, etc.

OVERALL DIMENSIONS in mm

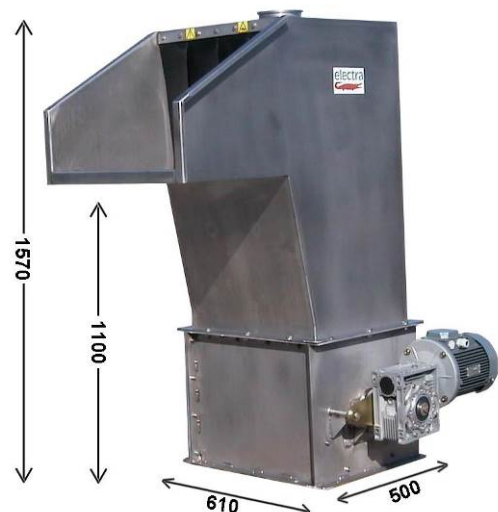
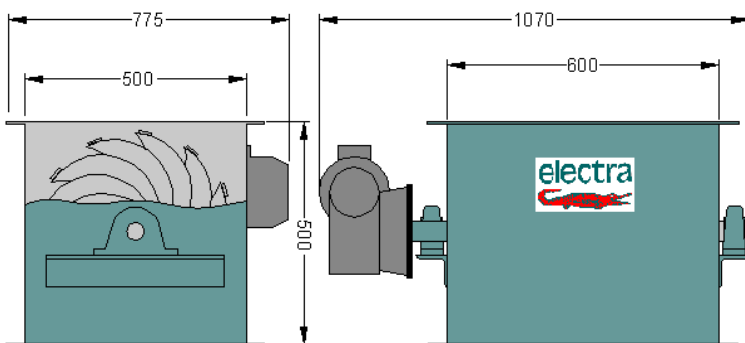

Lump breaker with feed hopper

The technical specifications may be subject to change without notice



47170 POUDENAS - FRANCE

Tel.: +33 (0)5 53 65 73 55

Fax: +33 (0)5 53 97 33 05

e-mail: electra@electra.fr

Internet: www.electra.fr