

PELLET PRESS 350 - 420



for the production of pellets for animal feedstuffs, aquaculture,
organic fertilisers, biomass, etc.

SPECIFICATIONS

- Double motor-drive system
- Main shaft in forged steel.
- Semi-automatic lubrication system.

DATA TYPE	Motor power (kW)	Flow Rate (t/h)	Die Ø (mm)	Pellet size (mm)	No. of rollers	Feeder power (kW)	Packager power (kW)	Steam Temp (°C)	Working Temp	Steam pressure (Mpa)
MUZL350-I								130-150	< 90	0.1-0.4
MUZL350-II	30 X 2	2-6	Ø350	Ø2-Ø12	2	0.75	3			
MUZL350-X	30 X 2	0.5-1.5	Ø350	Ø1.5-Ø2.5	2	0.75	3			
MUZL420-I	37 X 2	2.5-7.5	Ø420	Ø2-Ø12	2	1.5	7.5			
MUZL420-II	45 X 2	3-9	Ø420	Ø2-Ø12	2	1.5	7.5			
MUZL420-III	55 X 2	3-11	Ø420	Ø2-Ø12	2	1.5	7.5			
MUZL420-X	55 X 2	1-3	Ø420	Ø1.5-Ø2.5	2	1.5	7.5			

X: shrimp/prawn pellets

Overall dimensions

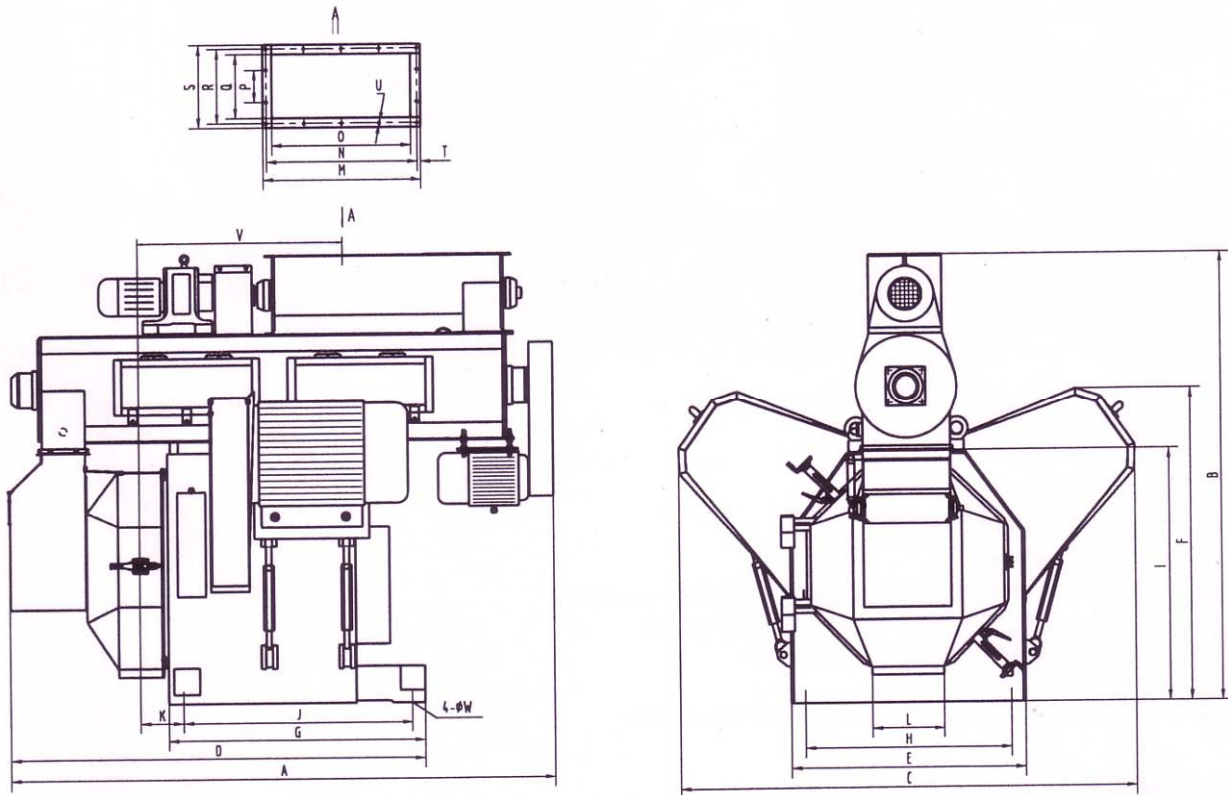

Model	A	B	C	D	E	F	G	H	I	J	K	L	M	N	O	P	Q	R	S	T	U	V	W
MUZL350	2125	1710	1640	1505	780	1160	880	600	950	780	160	240 × 195	517	3 × 134.5	477	101	263	305	345	84	10- φ 9	1602	4- φ 22
MUZL420- III (II / X)	2550	2100	2120	1926	1084	1455	1200	952	1180	1060	200	330 × 205	730	4 × 175	645	150	300	350	390	15	14- φ 9.6	964	4- φ 26
MUZL420- I	2550	2100	2120	1926	1084	1455	1200	952	1180	1060	188	330 × 205	730	4 × 175	645	150	300	350	390	15	14- φ 9.6	952	4- φ 26

The technical specifications may be subject to change without notice



47170 POUDENAS - FRANCE

Tel.: +33 (0)5 53 65 73 55

Fax: +33 (0)5 53 97 33 05

e-mail: electra@electra.fr

Internet: www.electra.fr