

PRESSE A GRANULER 350 - 420



**pour la granulation des aliments du bétail, aquaculture,
engrais organiques, biomasse, etc...**

CARACTERISTIQUES

- Système de double motorisation
- Arbre principal en acier forgé.
- Système de graissage semi-automatique.

DONNEES TYPE	Puissance moteur (kW)	Débit (t/h)	Ø filière (mm)	Taille des granulés (mm)	Nb de rouleaux	Puissance alimentateur (kW)	Puissance du conditionneur (kW)	Temp. Vapeur (°C)	Temp. De travail (°C)	Pression de la vapeur (Mpa)
MUZZ350-I								130-150	< 90	0.1-0.4
MUZZ350-II	30 X 2	2-6	Ø350	Ø2-Ø12	2	0.75	3			
MUZZ350-X	30 X 2	0.5-1.5	Ø350	Ø1.5-Ø2.5	2	0.75	3			
MUZZ420-I	37 X 2	2.5-7.5	Ø420	Ø2-Ø12	2	1.5	7.5			
MUZZ420-II	45 X 2	3-9	Ø420	Ø2-Ø12	2	1.5	7.5			
MUZZ420-III	55 X 2	3-11	Ø420	Ø2-Ø12	2	1.5	7.5			
MUZZ420-X	55 X 2	1-3	Ø420	Ø1.5-Ø2.5	2	1.5	7.5			

X: granulé pour crevettes

Côtes d'encombrement

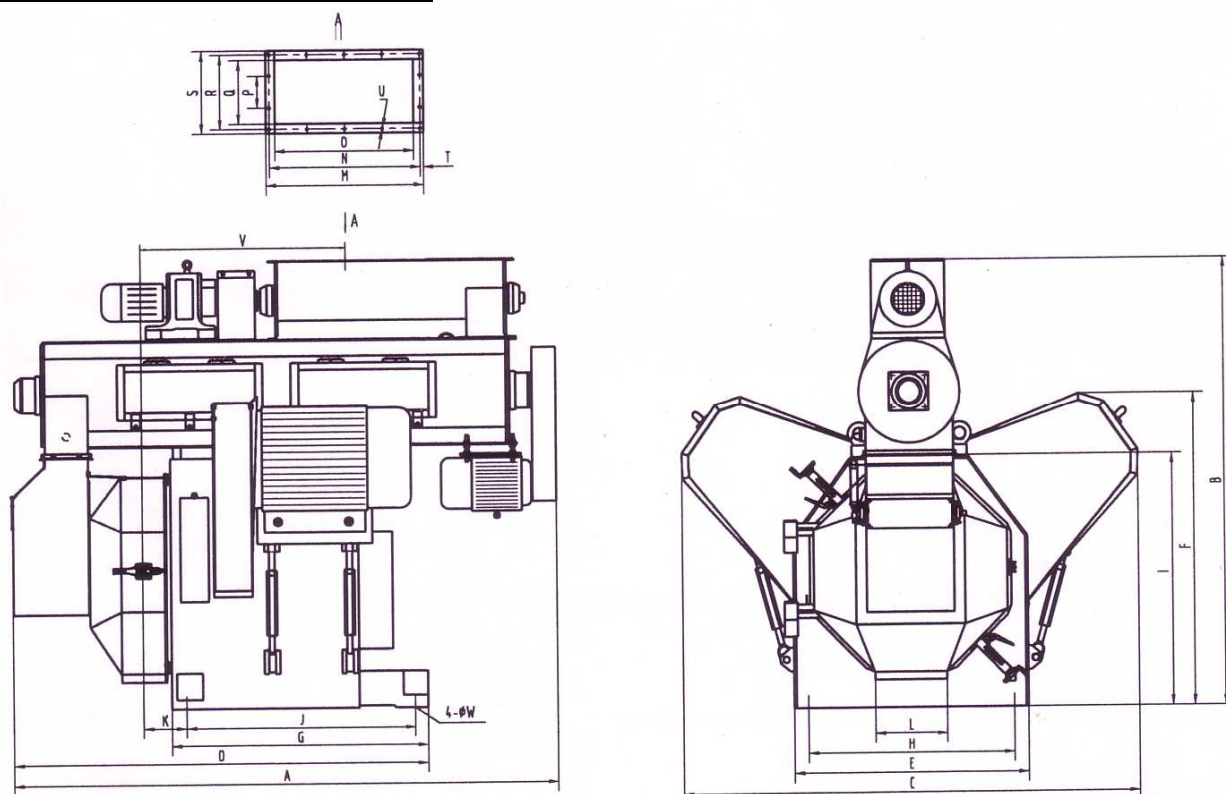

Model	A	B	C	D	E	F	G	H	I	J	K	L	M	N	O	P	Q	R	S	T	U	V	W
MUZZ350	2125	1710	1640	1505	780	1160	880	600	950	780	160	240 × 195	517	3 × 134.5	477	101	263	305	345	84	10- φ 9	1602	4- φ 22
MUZZ420- III (II / X)	2550	2100	2120	1926	1084	1455	1200	952	1180	1060	200	330 × 205	730	4 × 175	645	150	300	350	390	15	14- φ 9.6	964	4- φ 26
MUZZ420- I	2550	2100	2120	1926	1084	1455	1200	952	1180	1060	188	330 × 205	730	4 × 175	645	150	300	350	390	15	14- φ 9.6	952	4- φ 26

Les caractéristiques techniques restent modifiables sans préavis



47170 POUDENAS - FRANCE

Tél.: 05 53 65 73 55

Fax: 05 53 97 33 05

e-mail: electra@electra.fr

internet : www.electra.fr