

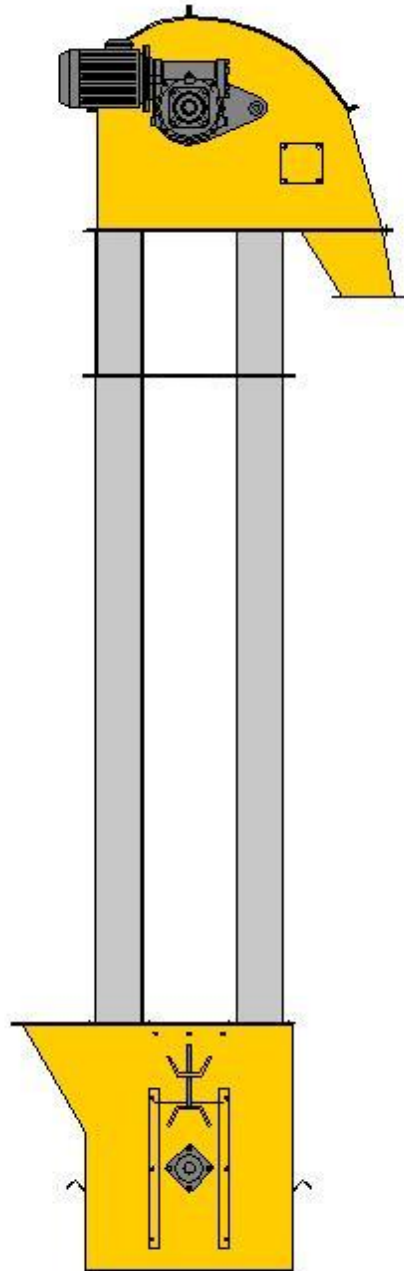

BUCKET LIFTER



FOR HANDLING BULK PRODUCTS:

Cereals, pellets, meals, etc.

SPECIFICATIONS

CONSTRUCTION	<p>Top and bottom: in painted steel, access hatch, self-cleaning squirrel cage drum on self-aligning flange bearing, belt tension adjustment.</p> <p>Ducts: in galvanised steel, with rear removable panel and spacer strut</p>
FEED	Square inlet 160 for feed on rising section
SPEED OF ROTATION	standard: 2.35 m/s
MOTORISATION	1.5 kW (2 HP)
DRIVE	Motor worm drive unit with hollow shaft
BUCKETS	Type 10 on rubber webbing with 8 buckets/metre
HEIGHT	From 6 to 12 m – see label
ACCESSORIES	<ul style="list-style-type: none"> - 2-, 3- or 4-direction Outlet hopper, - Revolving outlet

Flow rate 15 to 20 t/h

DIMENSIONS

Useful height	A	B
6 m	5.72 m	4.84 m
7 m	6.58 m	5.71 m
8 m	7.65 m	6.77 m
9 m	8.51 m	7.64 m
10 m	9.58 m	8.71 m
11 m	10.45 m	9.57 m
12 m	11.51 m	10.64 m

EXAMPLE OF USE

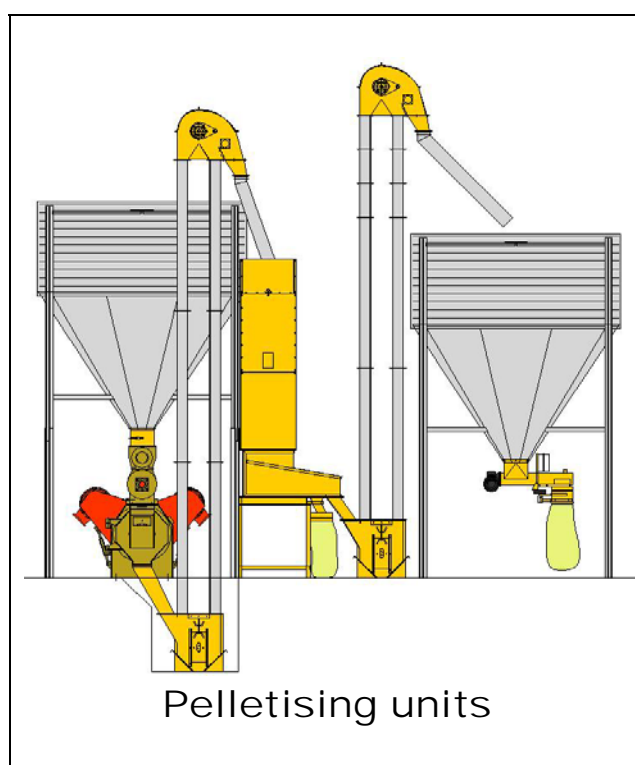

47170 POUDENAS - FRANCE

Tel.: +33 (0)5 53 65 73 55

Fax: +33 (0)5 53 97 33 05

e-mail: elevage@electra.fr

Internet: www.electra.fr