



PELLETISING UNITS  
0.5 to 1 T/H - 1 to 2 T/H



For pelletising animal feedstuffs

# PRESS SPECIFICATIONS

		PRD 250	PRD 300
POWER	MAIN MOTOR	22 kW (30 HP)	45 kW (60 HP)
	PACKAGER	2.2 kW (3 HP)	
	FEEDER	1.5 kW (2 HP)	
TRANSMISSION	V-belts under protective housing		
NUMBER OF ROLLERS	2		
INSIDE DIAMETER OF DIE		250 mm	300 mm
OPTIONS	<ul style="list-style-type: none"> <li>- Feed auger Ø100, motor 1.1kw with bag loading hopper</li> <li>- Flowmeter for integrating water fixed to the packager</li> <li>- Collection belt len. 7m at 45°</li> <li>- Vertical cooler with integrated sifter</li> </ul>		

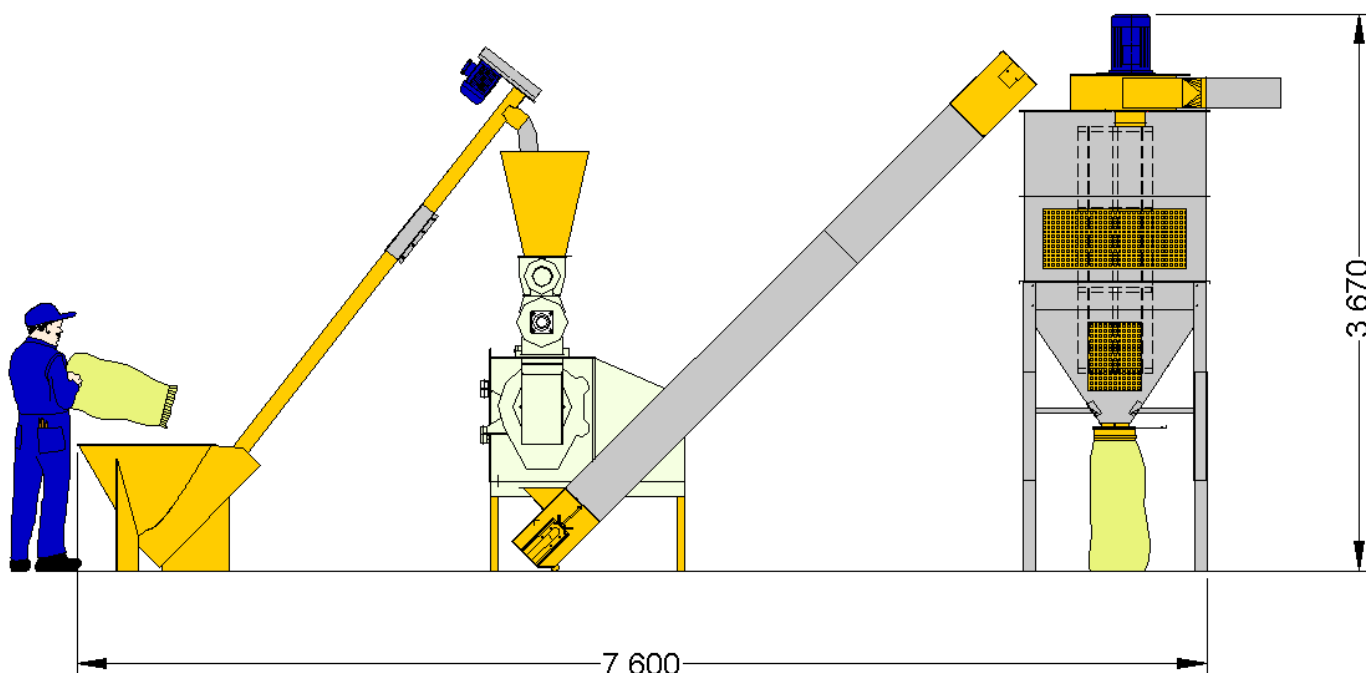

**INSTALLATION EXAMPLE:**

**PRD 250 PRESS + "ECO" COOLER**

The technical specifications may be subject to change without notice



**47170 POUDENAS - FRANCE**

Tel.: +33 (0)5 53 65 73 55

Fax: +33 (0)5 53 97 33 05

e-mail: [electra@electra.fr](mailto:electra@electra.fr)

Internet: [www.electra.fr](http://www.electra.fr)