



COMBINED RICE MILLING ASSEMBLY



COMBINED
RICE MILLING
ASSEMBLY
ELECTRICAL VERSION

SPECIFICATIONS

	ROLLER HULLER CL 1000	LIFTING AUGER	POLISHER WHITENER CCB 700
CONSTRUCTION	2 rubber rollers Ø222x152 mm	<ul style="list-style-type: none"> - with input hopper for hulled rice on output from the huller - fixing collar to the polisher hopper 	
MOUNTING FRAME	with V-belt drive and tensioning system		with V-belt drive and tensioning system
DIMENSIONS (LxWxH)	700x660x1350		1080x450x800
ELECTRICAL VERSION	electric motor 7.5 kW (10 HP)	electric motor 0.75 kW (1 HP)	electric motor 7.5 kW (10 HP)
EQUIPMENT	3 circuit breakers for starting and to provide thermal cutout for the 3 electric motors (wired)		
ENGINE-POWERED VERSION	VIKYNO RV 125-2N diesel engine, 12 HP at 2400 RPM		VIKYNO RV 125-2N diesel engine, 12 HP at 2400 RPM
	Hulling efficiency: 70/90%		% rice grains split: 20/25%
FLOW RATE	PADDY RICE: 1000 Kg/h WHITE RICE: 700 Kg/h		



**ROLLER HULLER CL 1000
ENGINE-POWERED VERSION**

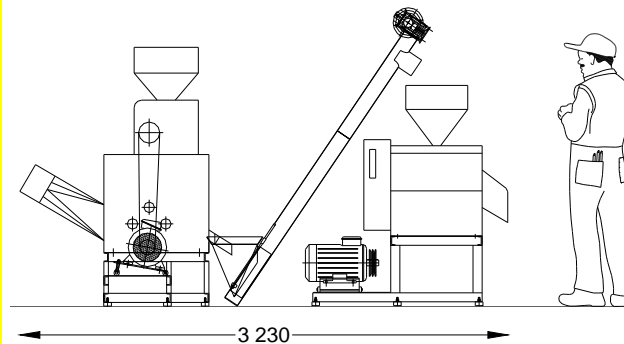

Equipment intended for export outside the EC



**POLISHER WHITENER
CCB 700 ENGINE-
POWERED VERSION**



47170 POUDENAS - FRANCE
 Tel.: +33 (0)5 53 65 73 55
 Fax: +33 (0)5 53 97 33 05
 e-mail: tropical@electra.fr
 Internet: www.electra.fr