



EXPORT FEED PRODUCTION PLANT 2 T/H to 3 T/H



FOR THE PRODUCTION OF FEEDSTUFFS IN BATCHES OF 1000 kg

EQUIPMENT

Cereal silo with SG2 grinding mill:

Galvanised, capacity 800 litres (1.25 x 1.25 x 1.25)
Fitted with a suction flow rate regulator
with manual adjustment flap and magnetic shielding

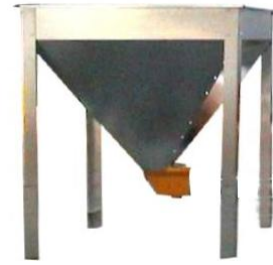

Type BC 15 kW (20 HP) grinding mill:

Suction, discharge
3000 rpm, 8 hammers, 2 grids Ø6 and 8 mm
Interchangeable wear plates, on anti-vibration mounts



Type MH 3000 horizontal mixer:

Rotor with double reverse pitch blades on struts.
7.5 kW (10 HP) motor-gearbox unit
Useful capacity 2200 litres in batches of 1000 to 1200 kg.
1 pneumatic inlet Ø150,
1 air decompression bag
1 auger inlet on cover
1 discharge valve under the tank
1 helmet valve at the bottom of the tank for bagging-off

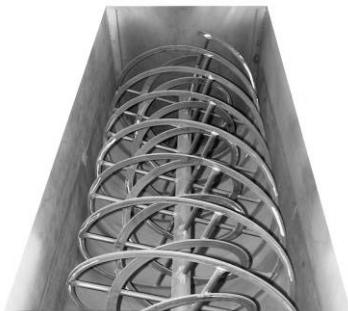

Reverse pitch spiral blades



Helmet valve



Mineral auger:

Diameter 100 mm, 1.1 kW motor.
Conical loading hopper, protective grid, flow control flap.
Leaktight connection on mixer.



OPTIONS

FOR 3 TONNES/HOUR

BC S 22 kW grinding mill:

With corresponding electrical switchboard
Suction, discharge
3000 rpm, 24 hammers, 2 grids Ø6 and 8
Interchangeable wear plates,
On anti-vibration mounts



FOR THE DOSING OF PRODUCTS TO BE MILLED

WEIGHING VERSION II

Functions: Tare, reset, aggregate recall, display of weight without programming.

1 indicator in plastic box, 2 m mains lead + plug

4 sensors provided with:

5 m cable per sensor

1 leaktight junction box

1 connection cable length 10 m



Indicator



Sensor

FOR PACKAGING

PE 150 weighing platform:

350 x 450 mm, max load 150 kg, accuracy 20g

1 indicator in plastic box IP 65

220 V single phase power supply,

Internal rechargeable battery



Portable stitcher:

For paper, polypropylene and jute bags.

Delivered with maintenance kit: oil can, set of wrenches,

1 Screwdriver, 1 set of carbon brushes

1 thread spool and 3 needles.



OVERALL DIMENSIONS

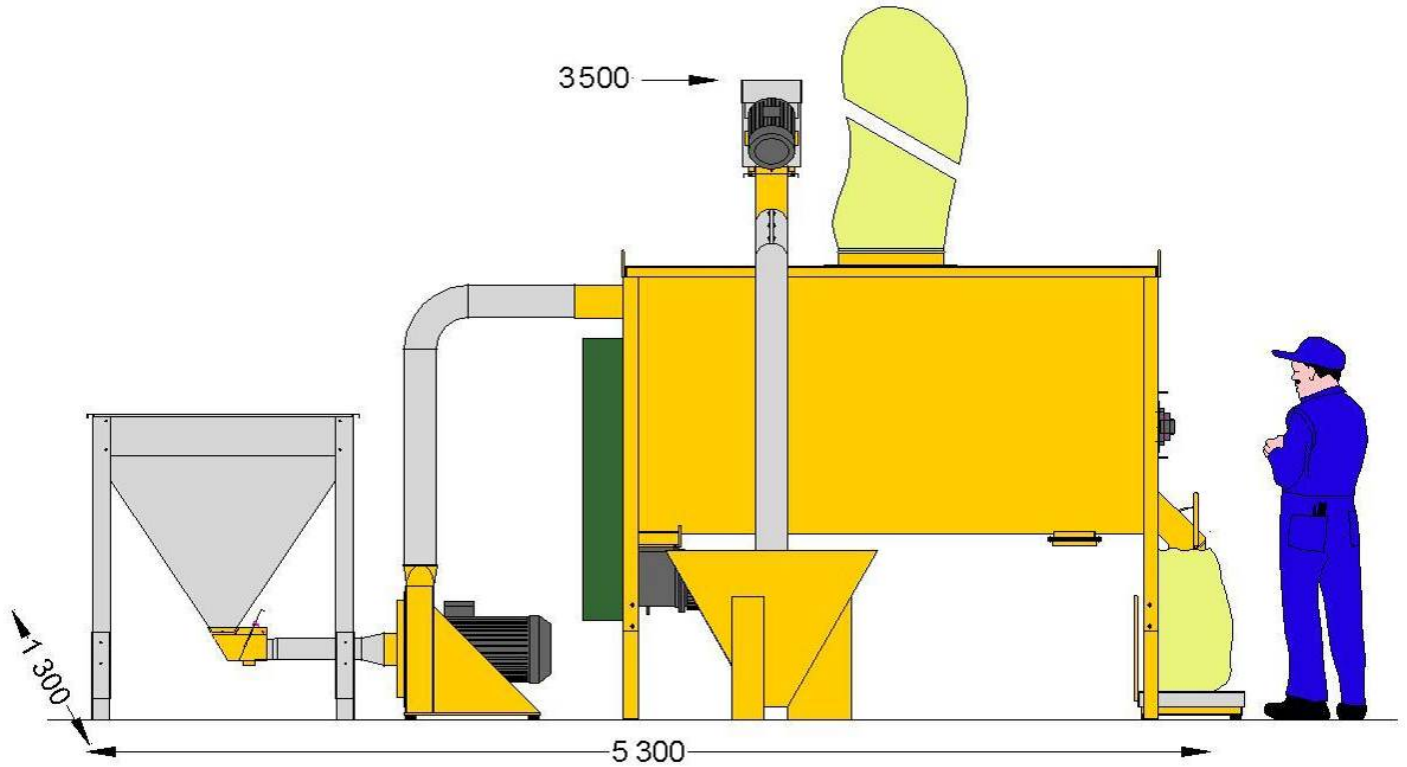

	STANDARD	WITH OPTION
TOTAL INSTALLED ELECTRICAL POWER:	24KW	31 KW
PACKAGING:	- 1 pallet 1.3m x 0.8m x 1.4m - 1 pallet 1.2m x 1m x 1.1m - 1 package 2.9m x 1.2m x 1.9m	weight: 260 kg weight: 50 kg weight: 1 T 070kg



47170 POUDENAS - FRANCE

Tel.: +33 (0)5 53 65 73 55

Fax: +33 (0)5 53 97 33 05

electra@electra.fr/ www.electra.fr

Skype: electra47170